

2016

Products & Systems

FURUNO NORGE

MARPORT



Contents

Pricing & Specifications

Introduction	4	Catch Sensor	17
Seine Explorer SE150	10	Rip Sensor	18
Seine Explorer SE050	11	Trawl Explorer TE155	19
Seine Explorer SE100	12	Mini Trawl Explorer TE070	20
Speed Explorer SPE155	13	/TE075	20
Bottom Explorer BE100		3n1 Trawl Speed &	
/BE150	14	Grid Sensor	21
Catch Explorer CE100		Multifunction Door	
/CE150	15	Sensors	22–24
Temp/Depth Sensors	16		

Marport Accessories

M3 Receiver System	25
M4 Receiver System	26
Hydrophones & Accessories	27
Thru-Hull Penetrations	28
Chargers & Adapters	29
Bridge Software –	
Marport Scala	30
Terms & Conditions/ Limited Warranty	31–32





Marport designs and manufactures catch control and net monitoring sensors, echo sounders, current profilers and sonar for the world's fishing fleet







Our solutions improve operational efficiency, reduce waste and increase catch quality



New Sensor solutions

	Bottom Trawl	Danish Seining	Pelagic Trawl	Purse Seining	Twin Rig	Triple Rig
 Seine Explorer SE150 (page 10)						
 Seine Sounder SE050 (page 11)						
 Seine Depth Sensor SE100 (page 12)						
 Bottom Explorer BE100 (page 14)						
 Catch Explorer CE150 (page 15)						
 Speed Explorer SPE155 (page 13)						

Sensor solutions

	Bottom Trawl	Danish Seining	Pelagic Trawl	Purse Seining	Twin Rig	Triple Rig
 <p>Trawl explorer TE155 (page 19)</p>	●	●	●	○	●	●
 <p>Mini trawl explorer TE075 (page 20)</p>	●	●	●	○	●	●
 <p>Multifunction Door (Spread) Sensor (page 22)</p>	●	●	●	○	●	●
 <p>Multifunction Door Sounder (page 24)</p>	●	○	●	○	●	●
 <p>3n1 Trawl Speed & Grid Sensor (page 21)</p>	●	●	●	○	●	●
 <p>Catch Sensor (page 17)</p>	●	●	●	○	●	●
 <p>Rip Sensor (page 18)</p>	●	●	●	○	●	●
 <p>Temp/Depth Sensors (page 16)</p>	●	●	●	●	●	●



Seine Explorer SE150

New product



Mounted on the lead line of a purse seine in a robust protective steel case, the Seine Explorer relays data back to the wheelhouse as a purse seine is shot away and throughout the fishing operation. It has been designed to incorporate omnidirectional uplink technology that ensures no loss of signal throughout the fishing operation, starting the moment the purse seine is shot away.

The skipper is shown an echogram of the shot as it takes place, displaying the distance to the seabed and a Scanmar-compatible digital readout of the depth of water above and below the leadline.

For purse seining in shallow water, Marport's Seine Explorer is an essential tool that ensures the gear can be kept safely clear of ground obstructions so gear damage can be avoided, and in both deep and shallow water the upward-seeking option that provides distance to the surface gives the skipper an accurate indication of the sinking speed of the leadline.

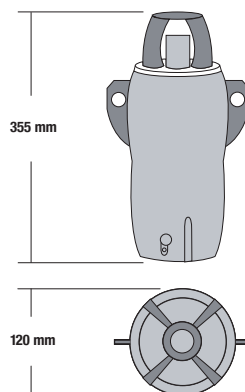

Technical Specifications

Uplink Frequency	30 to 60 kHz	Temp Measurement Range	-5°C to +25°C
Uplink Beamwidth	70°	Temp Accuracy	±0.1°C
Range to Vessel	2500 m	Battery Type	Lithium-Ion
Depth range	1600 m	Typical Battery Life	Up to 35 hours*
Pitch & Roll (Angle)	±90°	Charging Time	Standard: 8-12 hours** Fast Charge: 4 hours
Pitch & Roll (Accuracy)	0.1°	Weight in Air	5.0 kg
Depth Resolution	0.1m with 0.1% accuracy	Weight In Water	0.9 kg
Update Rate	1-5 sec.	Warranty	2 years (Sensor & Battery) †
DEPTH range	1600 m		
Sounder Range (programmable)	5-160 m		
Sounder Broadband Frequency	120-210 kHz		

*Reference Only. Depends on functions enabled. Battery life may be extended using low power settings.

**Based on average charging time. Refer to the Battery Chargers Quick Reference Guide for further information.

† Marport Standard Marine Limited Warranty

Product list

Product number	Description
SE-150-W	A1 SE150 Omni Seine Explorer w/ Temp, Depth and VBAT

Seine Depth Sensor SE050

Relays data back to the wheelhouse as a purse seine is shot away and throughout the fishing operation



Mounted on the lead line of a Seine depth sensor in a robust protective steel case, the Seine depth sensor relays data back to the wheelhouse as a purse seine is shot away and throughout the fishing operation.

It has been designed to incorporate omnidirectional uplink technology that ensures no loss of signal throughout the fishing operation, starting the moment the purse seine is shot away.

A depth sensor does just what it says on the label, and these do so much more. Its primary function is to measure the depth of the gear relative to the surface, while also being able to relay information about the speed of the gear through the water as the gear is lifted or allowed to sink.

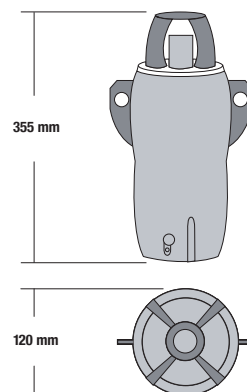

Technical Specifications

Uplink Frequency	30 to 60 kHz	Temp Measurement Range	-5°C to +25°C
Uplink Beamwidth	70°	Temp Accuracy	±0.1°C
Range to Vessel	2500 m	Battery Type	Lithium-Ion
Depth range	1600 m	Typical Battery Life	Up to 500 hours*
Pitch & Roll (Angle)	±90°	Charging Time	Standard: 8-12 hours** Fast Charge: 4 hours
Pitch & Roll (Accuracy)	0.1°	Weight in Air	5.0 kg
Depth Resolution	0.1m with 0.1% accuracy	Weight In Water	0.9 kg
Update Rate	DEPTH: 3-8 sec. TEMP: 3-16	Warranty	2 years (Sensor & Battery) †
Depth Range	300/600/1200/1800 m		

*Reference Only. Depends on functions enabled. Battery life may be extended using low power settings.

**Based on average charging time. Refer to the Battery Chargers Quick Reference Guide for further information.

† Marport Standard Marine Limited Warranty

Product number	Description
SE-50-W	A1 SE050 Omni Seine Depth Sensor
HOO-0-00	Height Option
TOO-0-00	Temp. Option
DOO-0-00	Depth Option
RPO-0-00	Pitch & Roll Option

Seine Sounder SE100

Relays data back to the wheelhouse as a purse seine is shot away and throughout the fishing operation



Mounted on the lead line of a purse seine in a robust protective steel case, the Seine Explorer relays data back to the wheelhouse as a purse seine is shot away and throughout the fishing operation. It has been designed to incorporate omnidirectional uplink technology that ensures no loss of signal throughout the fishing operation, starting the moment the purse seine is shot away.

The skipper is shown an echogram of the shot as it takes place, displaying the distance to the seabed and a Scanmar-compatible digital readout of the depth of water above and below the leadline.

For purse seining in shallow water, Marport's Seine Sounder is an essential tool that ensures the gear can be kept safely clear of ground obstructions so gear damage can be avoided, and in both deep and shallow water the upward-seeking option that provides distance to the surface gives the skipper an accurate indication of the sinking speed of the leadline.

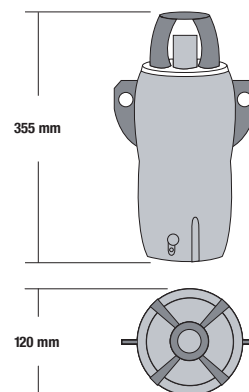

Technical Specifications

Uplink Frequency	30 to 60 kHz	Temp Measurement Range	-5°C to +25°C
Uplink Beamwidth	70°	Temp Accuracy	±0.1°C
Range to Vessel	2500 m	Battery Type	Lithium-Ion
Depth range	1600 m	Typical Battery Life	Up to 300 hours*
Pitch & Roll (Angle)	±90°	Charging Time	Standard: 8-12 hours** Fast Charge: 4 hours
Pitch & Roll (Accuracy)	0.1°	Weight in Air	5.0 kg
Depth Resolution	0.1m with 0.1% accuracy	Weight In Water	0.9 kg
Update Rate	1-5 sec.	Warranty	2 years (Sensor & Battery)†
Sounder range (programmable)	5-160 m		
Sounder Broadband Frequency	120-210 kHz		

*Reference Only. Depends on functions enabled. Battery life may be extended using low power settings.

**Based on average charging time. Refer to the Battery Chargers Quick Reference Guide for further information.

† Marport Standard Marine Limited Warranty

Product list

Product number	Description
SE-100-W	A1 SE100 Omni Seine Sounder w/ Height and Depth

Speed Explorer SPE155

Combines the functions of a trawl eye headline sounder with a trawl speed sensor



New product



This new addition to the Marport range combines a huge amount of functionality in a single headline-mounted package. The new Speed Explorer unit combines the functions of a trawl eye headline sounder with a trawl speed sensor to give a comprehensive data output direct to the skipper.

As well as the depth, temperature and pitch & roll data that has become a standard option with every virtually Marport sensor, the Speed Explorer offers an echogram, boosted from 1hz to 3hz to provide three updates per second. The data feeds providing information on water flow along the direction of the tow and across it are also upgraded in this unit to send an update every three seconds instead of every twenty seconds, giving the skipper an integrated overview of the trawl's opening, the flow and the effects of the currents around it.

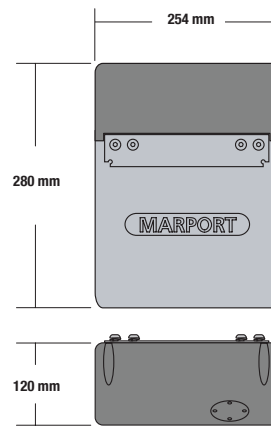

Technical Specifications

Uplink Frequency	30 to 60 kHz	Temp Accuracy	±0.1°C
Uplink Beamwidth	70°	Across Speed	0–6 knots
Range to Vessel	2500 m	Along Speed	±0.01 knots
Depth range	1600 m	Speed Resolution	0.1 knots
Pitch & Roll (Angle)	±90°	Battery Type	Lithium-Ion
Pitch & Roll (Accuracy)	0.1°	Typical Battery Life	Up to 48 hours*
Depth Resolution	0.1m with 0.1% accuracy	Charging Time	Standard: 8–12 hours** Fast Charge: 4 hours
Update Rate	1–5 sec.	Weight in Air	5.0 kg
Temp Measurement Range	-5°C to +25°C	Weight In Water	0.9 kg
Sounder Range (programmable)	5–160 m	Warranty	2 years (Sensor & Battery) †
Sounder Broadband Frequency	120–210 kHz		

*Reference Only. Depends on functions enabled. Battery life may be extended using low power settings.

**Based on average charging time. Refer to the Battery Chargers Quick Reference Guide for further information.

† Marport Standard Marine Limited Warranty

Product list

Product number	Description
SPE-155-W	A1 Trawl Speed/Trawl Explorer Dual function unit w/ Up/Down Echo, Along and Accross Speed Depth, Temperature and Pitch And Roll
TSS-1-MT	A1 TS Mounting Kit - Plate and Clamps
TSS-2-MT	A1 TS Mounting Axle

©2015–2016 MARPORT. "MARPORT", THE MARPORT LOGO AND SOFTWARE DEFINED SONAR ARE REGISTERED TRADEMARKS OF MARPORT. ALL OTHER BRANDS, PRODUCTS AND COMPANY NAMES MENTIONED ARE THE TRADEMARK AND PROPERTY OF ITS RESPECTIVE OWNERS ONLY. MARPORT IS A DIVISION OF AIRMAR TECHNOLOGY CORPORATION.

PERFORMANCE SPECIFICATIONS ARE ESTIMATES ONLY. ACTUAL RESULTS WILL VARY DEPENDING ON SEA STATE AND EXTERNAL FACTORS OUTSIDE MARPORT'S CONTROL.

BE100 /150 Bottom Explorer

Minimises lost fishing opportunities and ensures that the trawl is actively on the ground



New product



Fixed to a trawl's footrope, the Bottom Explorer provides a constant confirmation that the gear is in contact with the seabed, or an indication that the trawl has risen off the ground, giving the skipper the opportunity to respond by adjusting towing speed or warp length to place the gear back where it belongs. This minimises lost fishing opportunities and ensures that the trawl is actively on the ground.

Depth, temperature and pitch & roll data are also part of the package that sends ground contact data with a 3hz update rate three times per second to the wheel-house display. Unlike systems on the market that use a mechanical arrangement to sense ground contact, Marport have opted for an acoustic approach for greater reliability.

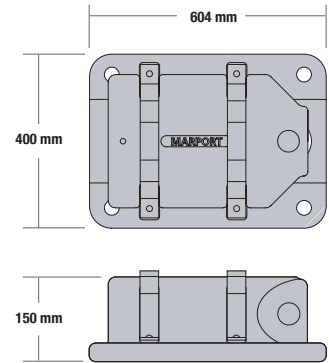

Technical Specifications

Uplink Frequency	30 to 60 kHz	Temp Measurement Range	-5°C to +25°C
Uplink Beamwidth	70°	Temp Accuracy	±0.1°C
Range to Vessel	2500 m	Battery Type	Lithium-Ion
Depth range	1600 m	Typical Battery Life	Up to 30 hours*
Pitch & Roll (Angle)	±90°	Charging Time	Standard: 8-12 hours** Fast Charge: 4 hours
Pitch & Roll (Accuracy)	0.1°	Weight in Air	5.0 kg
Depth Resolution	0.1m with 0.1% accuracy	Weight In Water	0.9 kg
Update Rate	1-5 sec.	Warranty	2 years (Sensor & Battery) †
Sounder range (programmable)	5-160 m		
Sounder Broadband Frequency	120 to 210 kHz		

*Reference Only. Depends on functions enabled. Battery life may be extended using low power settings.

**Based on average charging time. Refer to the Battery Chargers Quick Reference Guide for further information.

† Marport Standard Marine Limited Warranty

Product list

Product number	Description
BE-100-W	A1 BE100 Bottom Eye Echo Only
BE-150-W	A1 BE150 Bottom Explorer w/ Depth, Temp P&R, VBAT

CE100 /150 Catch Explorer

Provides a series of updates on the fish as they pass into the codend from the trawl mouth and through the belly



This gives a rolling echogram image of the volume of catch in addition to the data supplied by the usual codend sensors that are triggered as a certain amount has been caught. The Catch Explorer also features depth, temperature and pitch & roll data.

This downward-looking sensor is fitted on the top sheet of a codend or tunnel to all the skipper to monitor the contents of the codend in real time as the gear is fishing, providing a series of updates on the fish as they pass into the codend from the trawl mouth and through the belly.

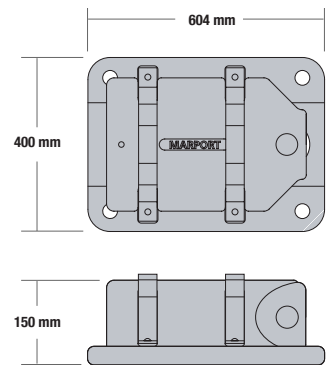

Uplink Frequency	30 to 60 kHz	Temp Measurement Range	-5°C to +25°C
Uplink Beamwidth	70°	Temp Accuracy	±0.1°C
Range to Vessel	2500 m	Battery Type	Lithium-Ion
Depth range	1600 m	Typical Battery Life	Up to 30 hours*
Pitch & Roll (Angle)	±90°	Charging Time	Standard: 8–12 hours** Fast Charge: 4 hours
Pitch & Roll (Accuracy)	0.1°	Weight in Air	5.0 kg
Depth Resolution	0.1m with 0.1% accuracy	Weight In Water	0.9 kg
Update Rate	1–5 sec.	Warranty	2 years (Sensor & Battery)†
Sounder range (programmable)	5–160 m		
Sounder Broadband Frequency	360 to 400 kHz		

*Reference Only. Depends on functions enabled. Battery life may be extended using low power settings.

**Based on average charging time. Refer to the Battery Chargers Quick Reference Guide for further information.

† Marport Standard Marine Limited Warranty

Product list

Product number	Description
CE-100-W	A1 CE100 Catch Eye Echo Only
CE-150-W	A1 CE150 Catch Explorer w/ Depth, Temp P&R, VBAT

Temp/depth sensors

A depth sensor does just what it says on the label, and these do so much more.



A depth sensor does just what it says on the label, and these do so much more. It's primary function is to measure the depth of the gear relative to the surface, while also being able to relay information about the speed of the gear through the water as the gear is lifted or allowed to sink.

Combined with the sensor's temperature function, this provides a range of data that gives the skipper the information needed to maintain the gear depth at its optimum level for the preferred conditions for particular species.

We see the depth/temperature sensor as a time-saving tool that cuts down on time wasted with the gear at the wrong location. It has a typical battery life of between 450 and 540 hours that can be extended depending on the power settings used.

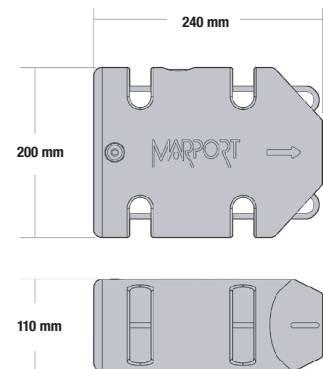

Technical Specifications

Uplink Frequency	30 to 60 kHz	Temp Measurement Range	-5°C to +25°C
Uplink Beamwidth	70°	Temp Accuracy	±0.1°C
Range to Vessel	2500 m	Battery Type	Lithium-Ion
Depth range	1600 m	Typical Battery Life	Up to 500 hours*
Pitch & Roll (Angle)	±90°	Charging Time	Standard: 8-12 hours** Fast Charge: 4 hours
Pitch & Roll (Accuracy)	0.1°	Weight in Air	5.0 kg
Depth Resolution	0.1m with 0.1% accuracy	Weight In Water	0.9 kg
Update Rate	DEPTH: 3-8 sec. /TEMP: 3-16 sec.	Warranty	2 years (Sensor & Battery) †
DEPTH range	300/600/1200/1800 m		

*Reference Only. Depends on functions enabled. Battery life may be extended using low power settings.

**Based on average charging time. Refer to the Battery Chargers Quick Reference Guide for further information.

† Marport Standard Marine Limited Warranty

Product list

Product number	Description
TD-5-00	Temperature Sensor ±0.1°
TD-6-00	Depth Sensor 0.1% accuracy
TD-7-00	Temp/Depth Sensor 0.1% accuracy combination
TD-8-00	Temp. ±0.1° Simrad PI Compatible
TD-9-00	Depth 0.1% FS Simrad PI
TD-10-00	Temp/Depth Sensor, Simrad PI Compatible
RPO-0-00	Pitch & Roll Option
CSO-0-00	Catch Explorer Option

©2015-2016 MARPORT. "MARPORT", THE MARPORT LOGO AND SOFTWARE DEFINED SONAR ARE REGISTERED TRADEMARKS OF MARPORT. ALL OTHER BRANDS, PRODUCTS AND COMPANY NAMES MENTIONED ARE THE TRADEMARK AND PROPERTY OF ITS RESPECTIVE OWNERS ONLY. MARPORT IS A DIVISION OF AIRMAR TECHNOLOGY CORPORATION.

PERFORMANCE SPECIFICATIONS ARE ESTIMATES ONLY. ACTUAL RESULTS WILL VARY DEPENDING ON SEA STATE AND EXTERNAL FACTORS OUTSIDE MARPORT'S CONTROL.

Catch Sensors



Would you shoot your gear without knowing when the trawl was starting to fill? Catch sensors have become key items of equipment, providing not just information on how fast the codend is filling up, but also giving vital indications on whether or not the gear is skewed, helping you avoid those lost tows. On top of all that, each catch sensor transmits a precise temperature reading to the wheelhouse.

Marport's catch sensors are among the most sophisticated on the market today, offering advanced single, dual or simultaneous operation to provide a reliable signal and to ensure uninterrupted communication with the gear. We provide high sensitivity and rapid response times, plus updates at 20 second intervals, along with a typical battery life of between 380 and 540** hours, extendable by enabling low power functions.

Our catch sensors are programmable on board and can be used as direct replacements for 40kHz (Simrad® and Scanmar®) and 70kHz (Simrad® and Wesmar®) sensors.

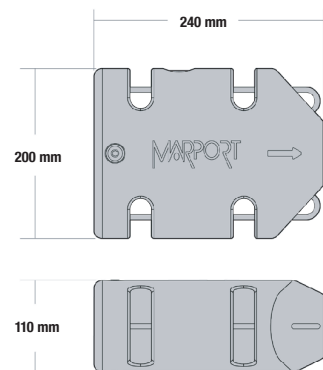

Technical Specifications

Uplink Frequency	30 to 60 kHz	Temp Measurement Range	-5°C to +25°C
Uplink Beamwidth	70°	Temp Accuracy	±0.1°C
Range to Vessel	2500 m	Battery Type	Lithium-Ion
Depth range	1600 m	Typical Battery Life	Up to 500 hours*
Pitch & Roll (Angle)	±90°	Charging Time	Standard: 8-12 hours** Fast Charge: 4 hours
Pitch & Roll (Accuracy)	0.1°	Weight in Air	5.0 kg
Depth Resolution	0.1m with 0.1% accuracy	Weight In Water	0.9 kg
Update Rate	DEPTH: 3-8 sec. /TEMP: 3-16 sec.	Warranty	2 years (Sensor & Battery)†
DEPTH range	300/600/1200/1800 m		

*Reference Only. Depends on functions enabled. Battery life may be extended using low power settings.

**Based on average charging time. Refer to the Battery Chargers Quick Reference Guide for further information.

† Marport Standard Marine Limited Warranty

Product list

Product number	Description
NFS-4-00	A1 Catch Sensor 70 khz (Simrad FS/Wesmar compatible)
NFS-5-00	A1 Catch Sensor 40 kHz (Marport/Scanmar compatible)
NFS-6-00	A1 Hybrid Catch Sensor 40/70 kHz Dual Frequency
NFS-7-00	A1 Catch Sensor PI
NFS-8-00	A1 Hybrid Catch Sensor 40/40PI kHz
DOO-0-00	Depth Option
RPO-0-00	Pitch & Roll Option
TDO-0-00	Temp. Option
CSO-0-00	Catch Explorer Option

©2015-2016 MARPORT. "MARPORT", THE MARPORT LOGO AND SOFTWARE DEFINED SONAR ARE REGISTERED TRADEMARKS OF MARPORT. ALL OTHER BRANDS, PRODUCTS AND COMPANY NAMES MENTIONED ARE THE TRADEMARK AND PROPERTY OF ITS RESPECTIVE OWNERS ONLY. MARPORT IS A DIVISION OF AIRMAR TECHNOLOGY CORPORATION.

PERFORMANCE SPECIFICATIONS ARE ESTIMATES ONLY. ACTUAL RESULTS WILL VARY DEPENDING ON SEA STATE AND EXTERNAL FACTORS OUTSIDE MARPORT'S CONTROL.

Would you shoot your gear without knowing when the trawl was starting to fill?

marport.com
MARPORT

Rip Sensor



This is our early warning system. The Rip Sensor is designed to be fixed to a trawl's belly or tunnel, where it sends an indication of any damage to the gear that could be letting fish escape.

The Rip Sensor operates on a 40kHz frequency, updates every 20 to 30 seconds, works all the way down to 1800 metres and has a typical battery life of 500 hours. As well as giving early warning of gear damage and loss of catch, the rip sensor also has a host of optional extra features, allowing it to transmit pitch and roll, depth and water temperature data to the wheelhouse.

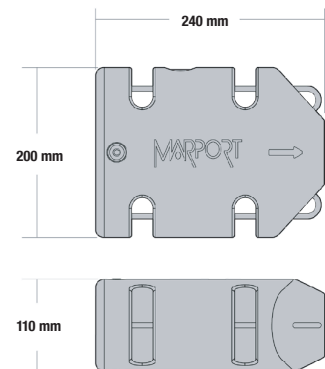

Technical Specifications

Uplink Frequency	30 to 60 kHz	Temp Measurement Range	-5°C to +25°C
Uplink Beamwidth	70°	Temp Accuracy	±0.1°C
Range to Vessel	2500 m	Battery Type	Lithium-Ion
Depth range	1600 m	Typical Battery Life	Up to 500 hours*
Pitch & Roll (Angle)	±90°	Charging Time	Standard: 8-12 hours** Fast Charge: 4 hours
Pitch & Roll (Accuracy)	0.1°	Weight in Air	5.0 kg
Depth Resolution	0.1m with 0.1% accuracy	Weight In Water	0.9 kg
Update Rate	DEPTH: 3-8 sec. /TEMP: 3-16 sec.	Warranty	2 years (Sensor & Battery) †
DEPTH range	300/600/1200/1800 m		

*Reference Only. Depends on functions enabled. Battery life may be extended using low power settings.

**Based on average charging time. Refer to the Battery Chargers Quick Reference Guide for further information.

† Marport Standard Marine Limited Warranty

Product list

Product number	Description
RS-1-00	Rip Sensor
RS-1-MTB	Rip Sensor Cage
TOO-0-00	Temp. Option
DOO-0-00	Depth Option
RPO-0-00	Pitch & Roll Option
CSO-0-00	Catch Explorer Option

©2015-2016 MARPORT. "MARPORT", THE MARPORT LOGO AND SOFTWARE DEFINED SONAR ARE REGISTERED TRADEMARKS OF MARPORT. ALL OTHER BRANDS, PRODUCTS AND COMPANY NAMES MENTIONED ARE THE TRADEMARK AND PROPERTY OF ITS RESPECTIVE OWNERS ONLY. MARPORT IS A DIVISION OF AIRMAR TECHNOLOGY CORPORATION.

PERFORMANCE SPECIFICATIONS ARE ESTIMATES ONLY. ACTUAL RESULTS WILL VARY DEPENDING ON SEA STATE AND EXTERNAL FACTORS OUTSIDE MARPORT'S CONTROL.

This is our early warning system.

marport.com
MARPORT

Trawl Explorer TE155

Marport's Trawl Explorer is your eye on the fishing gear.

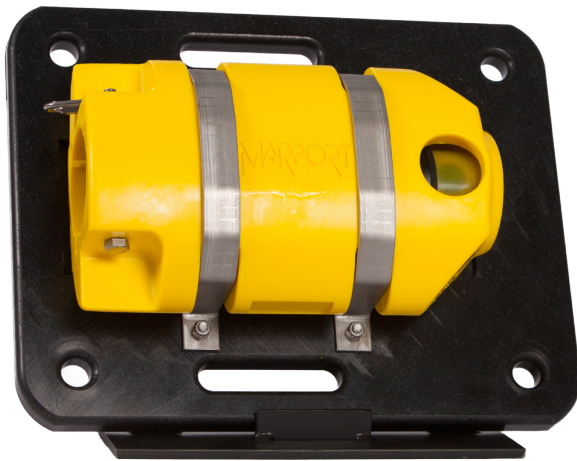

Marport's Trawl Explorer is your eye on the fishing gear, a sounder with a heavyweight suite of capabilities placed on your trawl's headline sending a wealth of information to the wheelhouse. This starts with an echogram of the trawl opening and fish passing into the gear, as well as depth, temperature and distance to the seabed or footrope, plus a visual representation of the footrope to seabed clearance if the gear is towed off the bottom.

The Trawl Explorer has a host of features for a variety of operating modes, and is a dual frequency unit. This allows the beamwidth to be selected from wide to narrow along with the most suitable of several sounding modes to suit the conditions.

Additional options are for a pitch and roll function to provide a realistic presentation of the gear's behaviour while trawling, and the Trawl Explorer can be fully programmed on board. Fully comparable with Furuno's CN-24 series displays, it can be a direct replacement for a CN-24 headline sounder.

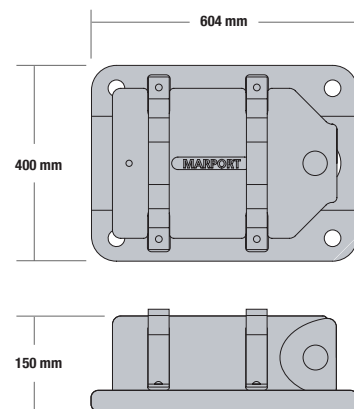

Technical Specifications

Uplink Frequency	30 to 60 kHz	Temp Measurement Range	-5°C to +25°C
Uplink Beamwidth	70°	Temp Accuracy	±0.1°C
Range to Vessel	2500 m	Battery Type	Lithium-Ion
Depth range	1600 m	Typical Battery Life	Up to 500 hours*
Pitch & Roll (Angle)	±90°	Charging Time	Standard: 8–12 hours** Fast Charge: 4 hours
Pitch & Roll (Accuracy)	0.1°	Weight in Air	5.0 kg
Depth Resolution	0.1m with 0.1% accuracy	Weight In Water	0.9 kg
Update Rate	DEPTH: 3–8 sec. /TEMP: 3–16 sec.	Warranty	2 years (Sensor & Battery) †
DEPTH range	300/600/1200/1800 m		

*Reference Only. Depends on functions enabled. Battery life may be extended using low power settings.

**Based on average charging time. Refer to the Battery Chargers Quick Reference Guide for further information.

† Marport Standard Marine Limited Warranty

Product list

Product number	Description
TE-155-W	TE155 Up/Down Sounding echo w/P&R Temp. and depth
RPO-0-00	Pitch & Roll Option

Mini Trawl Explorer TE075

Designed specifically with the needs of smaller vessels with modest-sized trawl gear in mind.



When the Mini-Trawl Explorer joined the Marport range, it was designed specifically with the needs of smaller vessels with modest-sized trawl gear in mind, although it also has a role as a tunnel-mounted down sounder for larger trawl gear.

Mounted on the headline, the Mini-Trawl Explorer gives the skipper an accurate image of the trawl opening and fish passing through the trawl mouth, plus depth, temperature, seabed distance and seabed clearance data.

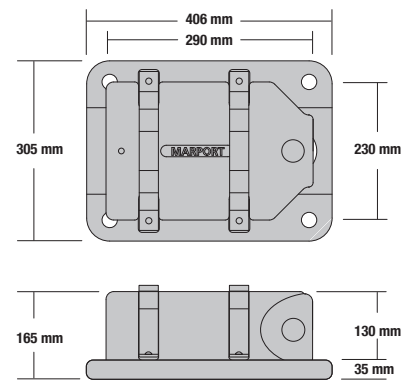

Technical Specifications

Uplink Frequency	30 to 60 kHz	Sounder Broadband Frequency	120 to 210 kHz
Uplink Beamwidth	70°	Temp Measurement Range	-5°C to +25°C
Range to Vessel	2500 m	Temp Accuracy	±0.1°C
Depth range	1600 m	Battery Type	Lithium-Ion
Pitch & Roll (Angle)	±90°	Typical Battery Life	Up to 35 hours*
Pitch & Roll (Accuracy)	0.1°	Charging Time	Standard: 8–12 hours** Fast Charge: 4 hours
Depth Resolution	0.1m with 0.1% accuracy	Weight in Air	5.0 kg
Update Rate	1–5 sec.	Weight In Water	0.9 kg
Sounder range (programmable)	5–160 m	Warranty	2 years (Sensor & Battery) †

*Reference Only. Depends on functions enabled. Battery life may be extended using low power settings.

**Based on average charging time. Refer to the Battery Chargers Quick Reference Guide for further information.

† Marport Standard Marine Limited Warranty

Product list

Product number	Description
TE-070-W	A1 TE070 Up/Down sounding echo only
TE-075-W	Up/Down Sounding echo w/P&R Temp. and depth
RPO-0-00	Pitch & Roll Option

3in1 Trawl Speed & Grid Sensor

Designed to give a trawler's skipper realistic information on how a grid is performing.

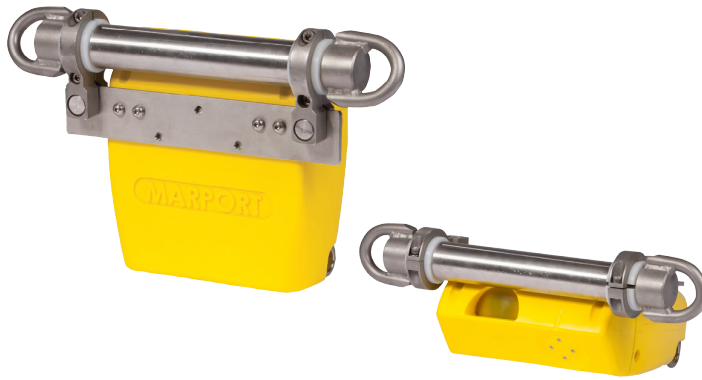

With a great many fisheries now subject to requirements to use selectivity devices, Marport's latest Trawl Speed & Grid sensor is designed to give a trawler's skipper realistic information on how a grid is performing, ensuring that a tow isn't lost due to some minor malfunction that could easily have been avoided with the right information available.

The Trawl Speed & Grid sensor is capable of measuring water flow in two axes, providing flow data as well as cross-current data, allowing corrections to be made to compensate for cross-currents when towing uphill or with mismatched warp lengths that can skew trawl geometry. Speeds of up to six knots can be monitored effectively and cross-currents of up to three knots are within the sensor's capabilities.

The sensor's fundamental functions in monitoring water flow through and across a trawl's tunnel are complemented by its advanced angle sensor, ensuring that the critical grid angle is maintained throughout the tow, and providing early warning of a grid becoming blocked and the target species deflected from reaching the codend. Updates for both flow and angle data are rapid.

As much as 90 hours of operation can be obtained from a single charge, with a fast charge option available when a quick turnaround is needed.

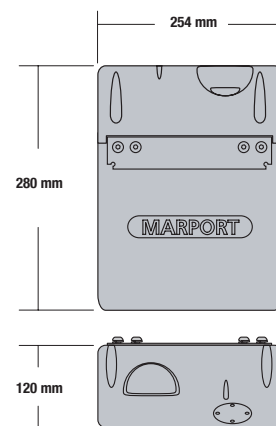

Technical Specifications			
Uplink Frequency	30 to 60 kHz	Temp Measurement Range	-5°C to +25°C
Uplink Beamwidth	70°	Temp Accuracy	±0.1°C
Range to Vessel	2500 m	Battery Type	Lithium-Ion
Depth range	1600 m	Typical Battery Life	Up to 200 hours*
Pitch & Roll (Angle)	±90°	Charging Time	Standard: 8-12 hours** Fast Charge: 4 hours
Pitch & Roll (Accuracy)	0.1°	Weight in Air	5.0 kg
Depth Resolution	0.1m with 0.1% accuracy	Weight In Water	0.9 kg
Update Rate	DEPTH: 3-8 sec. /TEMP: 3-16 sec.	Warranty	2 years (Sensor & Battery) †
DEPTH range	300/600/1200/1800 m		

*Reference Only. Depends on functions enabled. Battery life may be extended using low power settings.
 **Based on average charging time. Refer to the Battery Chargers Quick Reference Guide for further information.
 † Marport Standard Marine Limited Warranty

Product number	Description
TSS-0-00	A1 TS and Symmetri Sensor w/P&R
TSS-1-MT	A1 TS Mounting Kit – Plate and Clamps
TSS-2-MT	A1 TS Mounting Axle
GRD-0-00	A1 Grid Sensor w/flow speed w/P&R
GRD-2-MT	A1 Grid Sensor mounting Kit

Multifunction Door Spread Sensors

Marport's sensors are leaders in their field, capable of running and displaying all functions at any one time.



Marport's MFX Door Sensors use a master and slave configuration, communicating via a transverse wireless link on 110 or 144kHz. The master sensor interrogates the slave on the opposite trawl door, relaying data from both sensors to the catching vessel via a wireless uplink broadband transducer. As well as the door spread, this arrangement gives the skipper the full picture of each trawl door's performance, including pitch and roll function in two axes to indicate the inward/outward heel of each door as well as the forward/aft tilt, plus depth and water temperature.

Marport's sensors are leaders in their field, capable of running and displaying all functions at any one time.

Trawl door sensors are crucial to maintaining stable gear geometry, optimising catching capacity while also minimising the wasted time and energy that are by-products of having skewed gear, and contributing to keeping gear damage to a minimum. Data updates are as frequent as every three seconds, highlighting the importance of reliable trawl door data, providing immediate warning if the door cross over each other or if one door falls flat during a tow.

As well as information on door performance itself, data from the door sensors can often be an indicator of a problem elsewhere in the gear, such as a collapsed trawl, and our sensors are designed for all types of trawling that use doors. MFX door sensor battery life is between 90 and 200 hours for the master sensor and is as high as 300 hours for the slave unit, based on a standard charging time of 8 to 12 hours.

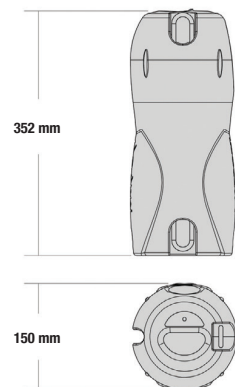

Technical Specifications

Uplink Frequency	30 to 60 kHz	Temp Measurement Range	-5°C to +25°C
Uplink Beamwidth	70°	Temp Accuracy	±0.1°C
Range to Vessel	2500 m	Battery Type	Lithium-Ion
Depth range	1600 m	Typical Battery Life	Up to 200 hours Master*
Pitch & Roll (Angle)	±90°	Charging Time	Standard: 8-12 hours** Fast Charge: 4 hours
Pitch & Roll (Accuracy)	0.1°	Weight in Air	5.0 kg
Depth Resolution	0.1m with 0.1% accuracy	Weight In Water	0.9 kg
Update Rate	DEPTH: 3-8 sec. /TEMP: 3-16 sec.	Warranty	2 years (Sensor & Battery)†
DEPTH range	300/600/1200/1800 m		

*Reference Only. Depends on functions enabled. Battery life may be extended using low power settings.

**Based on average charging time. Refer to the Battery Chargers Quick Reference Guide for further information.

† Marport Standard Marine Limited Warranty

Product list

Product number	Description
SS-18-00	Master (Door) Sensor 110
SS-19-00	Slave (Door) Sensor 110
SS-15-00	Master (Door) Sensor 144
SS-16-00	Slave (Door) Sensor 144
DOO-0-00	Depth Option
TOO-0-00	Temp. Option
RPO-0-00	Pitch & Roll Option
DDO-0-00	Double Distance Option
DCO-0-00	Dual Clump Option

©2015-2016 MARPORT. "MARPORT", THE MARPORT LOGO AND SOFTWARE DEFINED SONAR ARE REGISTERED TRADEMARKS OF MARPORT. ALL OTHER BRANDS, PRODUCTS AND COMPANY NAMES MENTIONED ARE THE TRADEMARK AND PROPERTY OF ITS RESPECTIVE OWNERS ONLY. MARPORT IS A DIVISION OF AIRMAR TECHNOLOGY CORPORATION.

PERFORMANCE SPECIFICATIONS ARE ESTIMATES ONLY. ACTUAL RESULTS WILL VARY DEPENDING ON SEA STATE AND EXTERNAL FACTORS OUTSIDE MARPORT'S CONTROL.

Mini Multifunction Door Spread Sensors

Designed to meet the needs of smaller trawlers towing semi-pelagic gear or flying their doors off the bottom.



MFX trawl door sensors are essential for keeping the gear correctly aligned, particularly working semi-pelagic or pelagic gear in which precision is critical to controlling the fishing gear and optimising fishing opportunities, ensuring that the gear geometry is maintained and providing early warning if there is a problem with the trawl, which in turn allows skipper to compensate or haul and fix the problem without wasting time and fuel.

Battery life is typically around 90 hours, based on a standard charging time of 8 to 12 hours, although endurance can be extended by using power-saving settings.

Designed to meet the needs of smaller trawlers towing semi-pelagic gear or flying their doors off the bottom, and using gear on which space is at a premium, Marport's multi-function XL-DD 'Small Frame' trawl door sensors have all the functionality of larger sensors, operating with a master and slave arrangement. The master sensor sends both sets of data to the catching vessel's wheelhouse, with update rates of as fast as every three seconds, providing the skipper with door spread, inward/outward heel, forward/aft tilt, depth and temperature data.

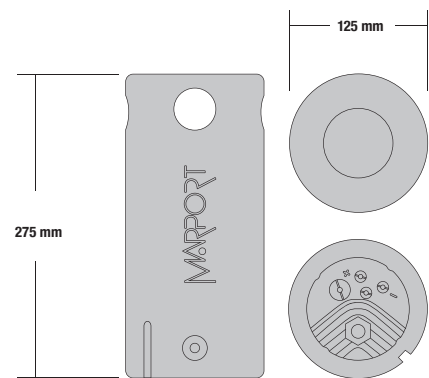

Technical Specifications

Uplink Frequency	30 to 60 kHz	Temp Measurement Range	-5°C to +25°C
Uplink Beamwidth	70°	Temp Accuracy	±0.1°C
Range to Vessel	2500 m	Battery Type	Lithium-Ion
Depth range	1600 m	Typical Battery Life	Up to 100 hours Master*
Pitch & Roll (Angle)	±90°	Charging Time	Standard: 8-12 hours** Fast Charge: 4 hours
Pitch & Roll (Accuracy)	0.1°	Weight in Air	5.0 kg
Depth Resolution	0.1m with 0.1% accuracy	Weight In Water	0.9 kg
Update Rate	DEPTH: 3-8 sec. /TEMP: 3-16 sec.	Warranty	2 years (Sensor & Battery) †
DEPTH range	300/600/1200/1800 m		

*Reference Only. Depends on functions enabled. Battery life may be extended using low power settings.

**Based on average charging time. Refer to the Battery Chargers Quick Reference Guide for further information.

† Marport Standard Marine Limited Warranty

Product list

Product number	Description
SS-08-00	XL-DD Master Door Sensor 144 kHz
SS-09-00	XL-DD Slave Door Sensor 144 kHz
DOO-0-00	Depth Option
TOO-0-00	Temp. Option
RPO-0-00	Pitch & Roll Option

Multifunction Door Sounder



This lightweight trawl door sensor has been developed specifically for trawlers towing demersal trawls spread with a pair of pelagic doors flown off the seabed. This DS-70-W sensor is there to provide rapid, accurate information, allowing the skipper to be sure of the clearance between the door shoes and the seabed and to maintain a steady distance.

This sounder is multi-function, single-frequency that includes depth, height and temperature indicators as standard. In addition to its prime function of checking the seabed distance, it functions as a down sounder to show fishing passing underneath towards the trawl, complementing codend sensors and codend sounders. This makes it possible to estimate volumes of fish as they appear at the front of the gear. It has a full echogram presentation in addition to simple digital clearance readout, with all functions accessible simultaneously.

Offered in high resolution narrow band with rapid updates, it has a battery life that typically reaches 60 hours with the standard 8-12 hour charge, while a 3.5 fast charge option is also available and low power settings can be selected to prolong battery life.

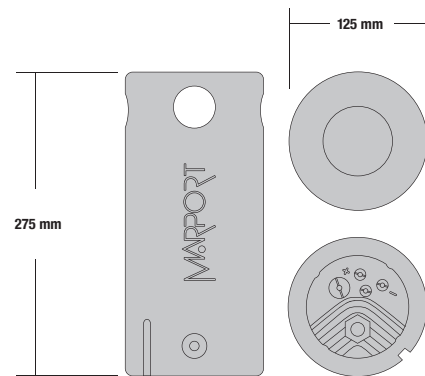

Technical Specifications

Uplink Frequency	30-60 kHz	Update rate	3-8 sec.
Uplink Beamwidth	70° (-3dB)	Battery Type	Lithium-Ion
Range to Vessel	2500 m	Typical Battery Life	Up to 60 hours*
Working depth	1600 m	Charging Time	Standard: 8-12 hours** Fast Charge: 3,5 hours
Pitch & Roll (Angle)	±90°	Weight in Air	3.9 kg
Optional Pitch & Roll Resolution	0.1 m	Weight In Water	0.8 kg
Sounder range (programmable)	5-160 m	Warranty	2 years (Sensor & Battery) †
Sounder Broadband Frequency	Broadband, 120-210 kHz		

Standard Configuration 165 kHz

*Reference Only. Depends on functions enabled. Battery life may be extended using low power settings.

**Based on average charging time. Refer to the Battery Chargers Quick Reference Guide for further information.

† Marport Standard Marine Limited Warranty

Product list

Product number	Description
DS-070-W	Door Sounder (XL-DD Configuration) w/standard accessories
DS-155-W	DS155W w/UDS echo only

Provides rapid,
accurate information.

marport.com
MARPORT

©2015-2016 MARPORT. "MARPORT", THE MARPORT LOGO AND SOFTWARE DEFINED SONAR ARE REGISTERED TRADEMARKS OF MARPORT. ALL OTHER BRANDS, PRODUCTS AND COMPANY NAMES MENTIONED ARE THE TRADEMARK AND PROPERTY OF ITS RESPECTIVE OWNERS ONLY. MARPORT IS A DIVISION OF AIRMAR TECHNOLOGY CORPORATION.

PERFORMANCE SPECIFICATIONS ARE ESTIMATES ONLY. ACTUAL RESULTS WILL VARY DEPENDING ON SEA STATE AND EXTERNAL FACTORS OUTSIDE MARPORT'S CONTROL.

M3 Receiver System

A highly sophisticated multi-function acoustic receiver.



Marport M3 is designed as a highly sophisticated multi-function acoustic receiver. It uses leading edge digital signal processing that we have combined with the smartest software available to make possible multi-channel operation without any compromise between transmission range and signal detection.

The M3 was conceived to meet the needs of smaller vessels, accommodating a series of full-function channels to allow simultaneous use of standard sensors, net sounders – including narrow band – and high resolution net sounders, all of which can be configured to suit the most advanced net monitoring system.

Product list

Product	Description
M3REC	Marport M3 Receiver
PC-0-03	Marport Mac Mini w/accessories and Scala Basic

M4 Receiver System

Our heavyweight acoustic receiver, combining the latest digital signal processing with the smartest software



The M4 is our heavyweight acoustic receiver, combining the latest digital signal processing with the smartest software. This means that true multi-function channel operation is available and there is no compromise between transmission range and signal detection.

We have designed the M4's multi-functional capacity to accommodate a series of full-function channels allowing simultaneous use of standard sensors, net sounders – including narrow band – and high resolution net sounders, all of these available over an extended frequency range and with selectable configurations for ultramodern net monitoring systems.

The M4 incorporates a host of features that are ready to be implemented, including sensor cross-referencing for positioning and distance, and sensor remote control. The M4 receiver is built to be configured and upgraded using standard software tools and operated with Windows® XP /Vista /7 Professional, Firefox® Web Browser and Java™ Runtime Environment (JRE).

Product list

Product number	Description
M4REC	Marport M4 Receiver
PC-0-04	Marport Mac Pro + Scala Full

Hydrophones & accessories

Crucial conduits that detect the signals from gear-mounted sensors



Marport's NHT Hydrophones are the crucial conduits that detect the signals from gear-mounted sensors. For full coverage under all conditions, we recommend that port and starboard hydrophones are used to ensure uninterrupted reception. We offer both towed paravane hydrophone and hull-mounted versions for trawl and seine use.

Our hydrophones are designed with dimensions to make them direct replacements for standard industry units, and we offer a comprehensive range of hydrophone types and configurations with passive and active options to meet virtually any requirement the fishing industry can throw at us.

Product list

Product number	Description
NC-1-01	40 kHz Single Frequency Pre-Amp Junction Box
NC-1-04	NHT Hydrophone – 35° x 55° (Replaces NC-1-02) <i>Active with integrated pre-amplifier and 25 metres of cable.</i>
NC-1-05	NHT Hydrophone – Passive Broadband - 35° x 55° (Replaces NC-1-03) <i>Dual element passive hydrophone. Developed for distance and position features of M4 Broadband Mbar receiver – with 25 meters of cable.</i>
NC-2-TEMP	NMEA Junction box with interconnect cable
NC-2-02	30-60 kHz Wideband Pre-Amp Junction Box
PA-1-01	Paravane Assembly
PA-1-02	Paravane Assembly w/active NHT hydrophone and 25 meters of cable.
Special Order	
PA-1-01-50	Paravane Assembly – Includes NHT active hydrophone w/50 meters cable
PA-1-01-75	Paravane Assembly – Includes NHT active hydrophone w/75 meters cable

©2015–2016 MARPORT. "MARPORT", THE MARPORT LOGO AND SOFTWARE DEFINED SONAR ARE REGISTERED TRADEMARKS OF MARPORT. ALL OTHER BRANDS, PRODUCTS AND COMPANY NAMES MENTIONED ARE THE TRADEMARK AND PROPERTY OF ITS RESPECTIVE OWNERS ONLY. MARPORT IS A DIVISION OF AIRMAR TECHNOLOGY CORPORATION.

PERFORMANCE SPECIFICATIONS ARE ESTIMATES ONLY. ACTUAL RESULTS WILL VARY DEPENDING ON SEA STATE AND EXTERNAL FACTORS OUTSIDE MARPORT'S CONTROL.

Thru-Hull Penetrations



Product list

Product number	Description
TH-1-01	Steel Thru-Hull Penetration for NHT NC-1-02 single active hydrophone <i>Includes washers, rubber gasket, and plug.</i>
TH-1-03	Steel Dual Cable Thru-Hull Penetration for NHT double active or passive hydrophones (please specify with order). <i>Includes washers, rubber gasket, and plug.</i>

Marport Basic Charger

Marport's Basic Standard Charger is an easy to use, lightweight, compact charger with its status indicated by a glowing light.

The standard charger is shipped with newly purchased sensors, and is capable of detecting instantly basic and/or fast charge sensor configurations. It includes UK, European, Australian and North American connectors, as well as replacement square pins for a Marport sensor's three-pronged connector.



Marport Multi-charger

Marport's heavy-duty multiple sensor charger is designed for simultaneous charging of up to four sensors with individual charging status indicator "glow" plugs. It has dual features for the standard basic (8 to 12 hour) charging cycle, and the fast charge configuration that allows a 70% charge in 1 hour and full charge in 3.5 hours. 110 /220 Vac.



MFX Door Pocket Adapters

Marport's Door Pocket Adapters are heavy-duty pockets for installation/welding into existing Trawl Doors to provide alignment during trawling operations. These are designed for MFX standard size and DD-XL small frame sensors supplied with standard hardware.



Product list

Product number	Description
BC-LiION-02	Marport Basic I Fast Charger 110/220
BC-LiION-03	Marport Basic II Fast Charger 110/220
BC-LiION-05	Marport Medusa II Fast Multicharger(4)

All Trawl Door pocket adaptors and supplied with technical information and Installing template

Bridge Software – Marport Scala

This is Marport's Advanced Trawl Monitoring System, designed with software that allows direct presentation page configuration with straightforward drag and drop, giving the user options to customise presentation to suit conditions at the time, or depending on the gear and sensor data type available.

Scala software is easily configurable and is organised by choosing existing gauges, histograms or 3D views, or by creating your own layout with any number of sensors displayable on the screen. This has the capability of comparing data from equivalent sensors using existing multiple historical line graphs.

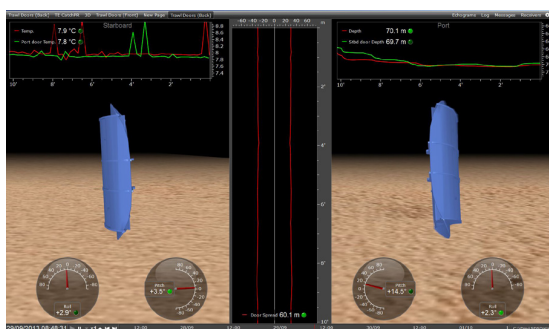
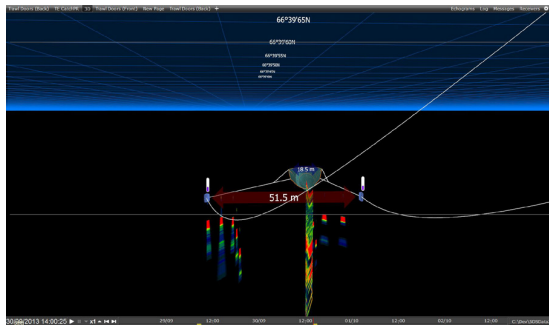
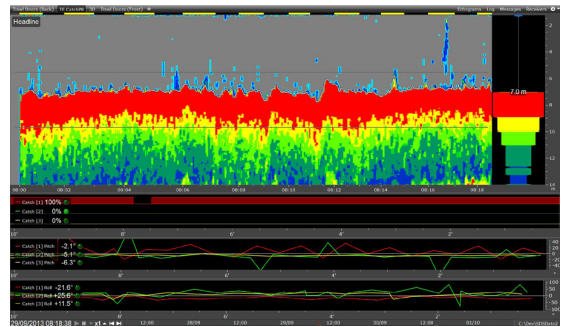
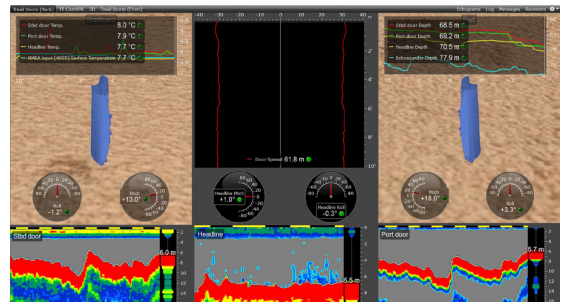

A key feature of Scala is that it is designed to meet tomorrow's requirements, already prepared for future expansion, ready to incorporate 3D simulation with bathymetry using a simple GPS data connection, and also has a range of standard data inputs and outputs, including full recording capability.

Scala offers up to four simultaneous echo-gram presentations on a single display page and playing back historical data is easily accessible, as are advance displays of 3D presentations in real time. This monitoring system offers unparalleled flexibility, complete with drag & drop possibilities in its layout, and with every window, graph and graph adjustable to suit the user's needs as they change. In addition, Scala is platform-independent, and is available for smartphones and tablet computers.

Product list

Product number	Description
46-102-01	Marport Scala Basic
46-102-02	Marport Scala Full

Terms & Conditions and Limited Warranty

Marport Deep Sea Technology

These Terms and Conditions of Sale and Limited Warranty and any order acknowledgment issued by Marport Deep Sea Technology ("Marport") a division of Airmar Technology Corporation, contain the entire and only agreement between the parties relating to the sale of products ("Products") by Marport to Buyer (Dealers, Distributors and end-users). The terms and conditions set forth herein take precedence over any additional or different terms and conditions propounded by Buyer, to which notice of objection is hereby given. Neither Marport's commencement of performance or delivery shall be deemed an acceptance of Buyer's additional or different terms and conditions. None of the terms and conditions contained herein may be added to, modified, superseded or otherwise altered except in writing by a duly authorized representative of Marport.

1. ACKNOWLEDGMENT/MODIFICATION/CANCELLATION OF ORDERS. All orders placed with Marport are concluded via written acknowledgment by Marport and are subject to the terms and conditions stated herein. In the case of a conflict between the terms and conditions stated herein and those appearing on the face of such acknowledgment, the latter shall control. Orders acknowledged by Marport may not be modified, rescinded, rescheduled or canceled unless authorized and acknowledged in writing by Marport. Orders may not be rescheduled after delivery by Marport to the carrier. If all or part of an order is canceled by such writing (the "Canceled Order"), in the absence of a contrary written agreement between Marport and Buyer, Buyer shall be required to pay Marport all costs committed or incurred by Marport as a consequence of such cancellation, including the cost of materials and labor, plus a cancellation fee of 25% of the total purchase price as a restocking charge for the Canceled Order.

2. PRICES. All prices are in the currency stated in the corresponding invoice, either European Union currency (€) or United States Dollars (US\$). Prices for Products shall be the then current price for such Products in effect at the time of Marport's written acknowledgment of an order. Prices are exclusive of all charges or levies of any nature, including all federal, state, municipal or other governmental excise, sales, use, value added, occupational, import duties, or similar taxes or tariffs now in force or enacted in the future (collectively, the "Additional Charges") and, therefore, are subject to an increase in an amount equal to any such Additional Charges that Marport may be required to collect or pay upon sale or delivery of Products purchased. When applicable, Additional Charges shall appear as separate items on Marport's invoices. All prices are subject to adjustment on account of changes requested by Buyer in specifications, quantities, shipment arrangements and configurations and the like.

3. PAYMENT TERMS; REVOCATION OF CREDIT. Except as otherwise agreed in writing by the parties, payment of the price and any Additional Charges shall be 1% ten (10) days, net thirty (30) days, and shall be made in accordance with the applicable Airmar written acknowledgment. All payments shall be made in U. S. currency. Payments not received within the payment terms shall be assessed a finance charge at the rate of one and one-half percent (1.5%) per month or the maximum rate permitted by law, whichever is less, starting from the invoice date. Buyer shall be liable for any costs or expenses incurred by Airmar in collecting any late payment, including, but not limited to, administrative and personnel costs, collection agency fees and expenses, court costs, and attorney's fees and expenses.

3.1 All Dealers and distributors, as well as all other referred as BUYER's including prospective buyers and dealers will be subject to a credit check by Marport before becoming an authorized dealer, a distributor or a buyer with credit terms, All applications completed and submitted to Marport, which reserves the right to refuse any application without explanations.

3.2 All price quotations, unless otherwise stated in writing by an authorized Marport representative, shall automatically expire thirty (30) calendar days from the date issued and may be cancelled or amended within that period upon notice to the Buyer. Marport reserves the right to change prices and pricing structures, any time, without advance notice

Marport reserves the right in its sole discretion to revoke, change or suspend any credit or payment terms already extended to Buyer or require full or partial payments in advance of any shipment or other performance, or otherwise defer, decline to make shipments and/or terminate the subject order without liability to Marport. If Marport believes in good faith that Buyer's ability to make payments called for by an order is impaired for any reason, Marport may cancel the order or any remaining balance thereof, and Buyer remaining liable to pay for any Products already shipped.

4. SHIPMENT. All Products shall be shipped as EX Works Marport Sales and Support offices worldwide facilities including from manufacturing facility located in Milford, New Hampshire, and in accordance to stated location in the corresponding invoice. All risk of loss of, or damage to, the Products and responsibility for all transportation expenses shall pass to Buyer upon delivery to the carrier, except that title and ownership shall remain with Marport until Buyer makes payment in full in accordance with the applicable order. Until such time as Buyer has fully performed, Marport shall have the unlimited right, without liability, to take possession of the Products, with or without notice, and to have all remedies of a secured party under the applicable provisions of the Uniform Commercial Code. Products invoiced and held by Marport for any reason shall be at Buyer's risk and expense. Delivery route shall be at the election of Marport, unless specifically designated by Buyer and acknowledged in writing by Marport. In no event shall the carrier be deemed an agent of Marport. Should delivery of any or all of the Products (or any other obligation of Marport) be delayed by events beyond Marport's control, whether or not foreseeable, Marport's time for performance shall be extended by the period of delay, or Marport may, at its option, cancel the order(s) without liability, Buyer remaining liable to pay for shipment(s) already completed.

5. LIMITED WARRANTY. Marport warrants to Buyer that all of the Products' electrical and mechanical parts are free from defects in workmanship and materials and shall conform to and perform in accordance with applicable Product specifications issued by Marport for a period of two (2) years from the date of shipment to Buyer. If the Buyer has provided to Marport supplemental specifications in writing prior to, or at time of order entry, and Marport has acknowledged in writing the supplemental specifications, then Marport warrants to Buyer that the Products' electrical and mechanical parts are free from defects in workmanship and materials and shall conform to and perform in accordance with applicable supplemental specifications for a period of two (2) years from the date of shipment to Buyer. Components supplied to Marport by Buyer for incorporation into the Products are not warranted by Marport.

This limited warranty does not apply to expendable parts and does not cover normal wear and tear. This limited warranty does not extend to any Products from which the serial number or other identifying markings has been removed or tampered with or any Products that have been damaged or rendered defective (a) as a result of accident, misuse, abuse, negligence, installation, act of God, disaster, impact, vessel grounding, pinched, cut or abraded cables, contact with strong solvents, or other external cause, (b) by the use of parts not manufactured or sold by Marport, or (c) by modification or service by anyone other than Marport or by a fully authorized dealer or distributor. Marport is not responsible for damage that occurs during installation or as a result of Buyer's failure to follow the instructions that come with the Products or by operation outside the usage parameters stated in the user and technical documentation that is supplied with the Products.

Marport will repair or replace, at its sole discretion, equipment determined by Marport to be defective in material or workmanship. This warranty applies to parts and labor for new equipment only and is applicable for up to a twenty four (24) month period starting the date the product is shipped to buyer. Replacement parts and products do not extend this original warranty period.

This warranty will not cover, nor will Marport be liable for costs associated with the removal and installation of sensor equipment, shipping, lost productivity costs, launching or removing the vessel from the water, business interruption costs, re-procurement costs, loss of profit or revenue, loss of data, promotional or manufacturing costs, overhead, injury to reputation or loss of customers or other incidental or consequential costs. In no event shall the maximum liability for Marport exceed the original purchase price of the goods determined to be defective.

Costs associated with replacement of sensors, including but not limited to mileage, custom duties, boat hauling and reinstallation labor, are specifically excluded from this limited warranty.

Buyer shall notify Marport in writing of any non-conformance or defects during the warranty period, obtain from Marport a return material authorization ("RMA") for the defective Product, and return the non-conforming Products to Marport, freight prepaid, within fifteen (15) days of receipt of the RMA, with a statement describing in reasonable specificity the non-conformity. Marport's exclusive obligation with respect to the non-conforming Products shall be, at Marport's option, to repair or replace the Products, if they are determined to be defective, or to issue a credit to Buyer, within thirty (30) days after receipt by Marport of the returned Products. Transportation charges on warranty must be prepaid by Buyer. Return surface transportation charges will be prepaid by Marport.

Buyer shall notify Marport of any non-conformance and submit a warranty claim with regard to Products that are damaged in transit within fifteen (15) days from the date of receipt.

NOTWITHSTANDING ANYTHING HEREIN TO THE CONTRARY, THE FOREGOING IS BUYER'S SOLE AND EXCLUSIVE REMEDY FOR BREACH OF WARRANTY BY MARPORT WITH RESPECT TO THE PRODUCTS. MARPORT MAKES NO OTHER WARRANTIES, ARISING FROM OPERATION OF LAW OR OTHERWISE, EXPRESS OR IMPLIED, INCLUDING ANY IMPLIED WARRANTIES OF MERCHANTABILITY, FITNESS FOR A PARTICULAR PURPOSE, OR NON-INFRINGEMENT, AND ALL OTHER WARRANTIES ARISING FROM COURSE OF DEALING OR USAGE ARE HEREBY EXCLUDED. IMPLIED WARRANTIES THAT MAY BE IMPOSED BY LAW ARE LIMITED IN DURATION TO THE LIMITED WARRANTY PERIOD SET FORTH HEREIN. BUYER PURCHASES AND ACCEPTS THE PRODUCTS SOLELY ON THE BASIS OF THE LIMITED WARRANTY EXPRESSED HEREIN. UNDER NO CIRCUMSTANCES SHALL MARPORT BE LIABLE BY VIRTUE OF THIS LIMITED WARRANTY OR OTHERWISE FOR ANY SPECIAL, INDIRECT, SECONDARY, PUNITIVE, EXEMPLARY, INCIDENTAL OR CONSEQUENTIAL DAMAGES (INCLUDING BUT NOT LIMITED TO LOSS OF PRODUCTION TIME OR OF ANTICIPATED REVENUE OR PROFITS TO ANY PERSON OR PROPERTY ARISING OUT OF THE USE OR INABILITY TO USE THE PRODUCTS), EVEN IF MARPORT HAS BEEN ADVISED OF THE POSSIBILITY OF SUCH DAMAGES. SOME STATES DO NOT ALLOW THE EXCLUSION OR LIMITATION OF INCIDENTAL OR CONSEQUENTIAL DAMAGES, SO THE ABOVE LIMITATION OR EXCLUSION MAY NOT APPLY TO YOU.

Any components or products not manufactured by Marport, including but not limited to any computer hardware or software, are not covered under the foregoing limited warranty. Any such components or products will only be covered by the warranties, if any, that accompany such components or products when shipped to Buyer. Under no circumstances shall Marport be liable for any losses or damages of any kind that arise as a consequence of any defect in any such components or products.

6. INSTALLATION. Buyer acknowledges that no installation, training or education shall be included in an order, unless specifically acknowledged in writing by Marport. In the event that Buyer receives any training from Marport with respect to the Products, such training shall be deemed personal to the person(s) receiving such training, and Buyer acknowledges that any person(s) receiving such training may not be capable of installing or operating the Products.

Terms & Conditions and Limited Warranty

Marport Deep Sea Technology

7. INSPECTION AND ACCEPTANCE. Buyer shall examine the Products as soon as possible after their arrival at Buyer's facility, and in any event not more than ten (10) days following the Products' arrival at Buyer's facility. Buyer shall notify Marport in writing (i) with respect to missing Products, immediately upon receipt by reference to the accompanying bill of lading, and (ii) with respect to Products that are damaged in transit, within fifteen (15) days from the date of receipt. The Products shall be deemed to conform to the applicable specifications despite minor discrepancies that are usual in the trade, and Buyer shall not be entitled to abatement of the price for such minor discrepancies. Where the Products are materially non-conforming, the remedies provided in the limited warranty set forth herein shall serve as Buyer's exclusive remedy. All Products shall be deemed accepted unless Marport is notified in writing of any defects within fifteen (15) days from the date of receipt.

8. PATENT, TRADEMARK AND COPYRIGHT INDEMNIFICATION. Marport agrees to and shall, at its option, either negotiate and/or defend all claims, suits or proceedings brought against Buyer if the manufacturing or design of the Products supplied hereunder infringes any patent, copyright or trademark of any third party, provided that Marport is notified promptly in writing and is given complete authority and information required for the defense or settlement of same. Marport shall pay all judgments, decrees, compromises, costs and expenses arising from any charge or infringement against Buyer, but Marport and its corporate shareholders (Airmar Technology Corporation) shall not be liable for compromises incurred or made by Buyer without Marport's prior written consent. The foregoing states the entire liability of Marport for any loss or damage whatsoever to Buyer arising from infringement of patents, trademarks or copyrights. Notwithstanding the foregoing, Marport shall have no obligation with respect to claims of infringement based upon the use of the Products in combination with other Products supplied either by Marport or others. Further, Marport shall have no obligation with respect to claims of infringement in the event that the manufacture or design of the Products is in accordance with specifications, designs or drawings furnished by customer or the claimed infringement is of any patent, trademark or copyright in which Buyer or any of its affiliates has an interest. Buyer hereby warrants and represents that any specifications, designs or drawings furnished by it or its representatives to Marport do not infringe upon any third-party patent, copyright, trademark or other intellectual property right of any third party, and agrees to indemnify and hold harmless Marport and its affiliates, successors and assigns from and against any costs, damages or liabilities that may arise due to any such infringement.

9. DEFAULT. Any of the following shall constitute an act of default hereunder: (1) a material breach of the Buyer, which breach has not been cured within thirty (30) days of the date of written notice of such failure given by Marport; or (2) the failure of Buyer to pay an invoice issued hereunder within the due date thereof; or (3) Buyer (i) admits in writing its inability to pay its debts generally as they become due, (ii) files a petition or has a petition filed against it in bankruptcy or any similar action under relevant bankruptcy or insolvency proceedings, (iii) makes an assignment for the benefit of its creditors, (iv) commences a proceeding for the appointment of a receiver, trustee, liquidator or conservator of itself or of the whole or any substantial part of its property, or (v) files a petition seeking reorganization, composition, liquidation, dissolution or similar arrangement under the federal bankruptcy laws or any other similar applicable law, statute or regulation of the United States or any country, state, county, province or other jurisdiction to which Buyer is subject. In the event of a default, Marport shall have the right to, in addition to any other remedies it may have at law or in equity, terminate all applicable orders, recover any and all monies that may be due, and repossess any Products sold hereunder.

10. LIMITATION OF LIABILITY. IN NO EVENT SHALL THE LIABILITY OF MARPORT FOR ANY AND ALL CLAIMS ARISING HEREUNDER EXCEED THE SUM OF BUYER'S PAYMENTS FOR THE PRODUCTS THAT ARE THE SUBJECT OF DISPUTE.

11. LICENSED SOFTWARE. Computer software or other licensed programs which may be required in connection with the use of Products, are provided by Marport to Buyer pursuant to a single user license, the royalty, terms and conditions of which are set forth on or in the container in which the software is packaged.

12. SUBSTITUTIONS AND MODIFICATIONS OF PRODUCTS. Marport may modify the specifications of Products designed by Marport and/or substitute substantially conforming Products, provided the modifications and/or substitutions do not adversely affect the performance of such Products.

13. GOVERNING LAW. These Terms and Conditions, although designed to comply with general terms of law from various countries where Marport's facilities are located, to the best of Marport's knowledge, shall be governed by the laws of the State of New Hampshire without reference to its principles of conflicts of law rules, including Article 2 of the Uniform Commercial Code as enacted in New Hampshire, and shall not be governed by the provisions of the United Nations Convention on Contracts for the International Sale of Goods. Any legal or equitable actions or proceedings arising out of or relating to the transactions contemplated hereby shall be brought in the State of New Hampshire, and both parties hereby irrevocably submit to the jurisdiction and venue of said courts.

14. ASSIGNMENT. Buyer shall not delegate any duties or assign any rights or claims hereunder without Marport's prior written consent, and any such attempt at delegation or assignment without Marport's prior written consent shall be void.

15. INTELLECTUAL PROPERTY. Marport intends to utilize proprietary information and manufacturing process ("Proprietary Information") in manufacturing the Products and in discharging its other responsibilities hereunder. Buyer acknowledges and agrees that, as between the parties hereto, the Proprietary Information is proprietary to Marport and its corporate shareholders (Airmar Technology Corporation) and constitutes a trade secret under the Uniform Trade Secrets Act as adopted in the State of New Hampshire. Buyer will acquire no rights to use and/or disclose the Proprietary Information by virtue of the utilization of Proprietary Information in the Products manufactured or sold to Buyer hereunder.

All designs, drawings, manuals, instructions, software, process programs and text in any format (the "Written Materials") provided to Buyer by Marport are the sole property of Marport or its licensors, are protected by copyrights and international laws regarding copyrights, and may not be mechanically or electronically duplicated, reverse engineered or reproduced without Marport's express written consent.

16. CONFIDENTIALITY. Buyer shall maintain in confidence all information and know-how disclosed by Marport, whether oral or in writing, that is either designated as proprietary and/or confidential or, by the nature of the circumstances surrounding disclosure, should in good faith be treated as proprietary and/or confidential ("Confidential Information"), provided that Buyer may disclose Confidential Information on a need-to-know basis to its employees and representatives who have been apprised of these non-disclosure obligations and agreed to be bound by them. Buyer shall use at least the same degree of care in safeguarding the Confidential Information as it uses in safeguarding its own information of a similar nature, subject to a minimum standard of reasonable diligence and protection. Buyer's obligation of non-disclosure hereunder shall not apply to Confidential Information that it can demonstrate by clear and convincing evidence: (a) is or becomes a matter of public knowledge through no fault of Buyer, (b) was or becomes available to Buyer on a non-confidential basis from a third party, provided that such third party is not, to Buyer's knowledge, bound by an obligation of confidentiality to the disclosing party with respect to such Confidential Information, (c) was independently developed by Buyer without reference to Confidential Information, or (d) is required to be disclosed by law, provided that Marport is promptly notified by Buyer in order to provide Marport an opportunity to seek a protective order. This provision is in addition to and not in limitation of any other agreement entered into by Marport and Buyer relating to the protection or nondisclosure of Confidential Information.

17. COMPLIANCE WITH EU ROHS DIRECTIVE 2002/95/EC Marport declares that to the best of its actual knowledge, the Products will be in compliance with the provisions of the EU ROHS Directive 2002/95/EC. This declaration is provided to facilitate Buyer's compliance with that Directive, and does not in any way expand upon or modify Marport's obligations under these Terms and Conditions of Sale.

18. COMPLIANCE WITH LAWS. The Buyer agrees to comply strictly with all export and/or import control laws and regulations of various countries, specifically those where Marport has Sales and Support offices and assumes sole responsibility for obtaining licenses to import, export or re-export Marport products. Dealers shall not directly or indirectly export any Marport product to any country to which such export or transmission is restricted or prohibited. The dealer shall also be responsible for any fees arising from; licensing fees, import/export fees or duties or similar taxes and fees charged by different jurisdictions and countries.

Buyer acknowledges that the Products are subject to regulation by United States government agencies that prohibit export or diversion of the Products, information about the Products, and derivatives of the Products to certain countries and certain persons (collectively, "U.S. Export Control Laws"). Buyer hereby represents, warrants and agrees that Buyer shall abide by, be bound by and strictly comply with all U.S. Export Control Laws as currently in effect and promulgated from time to time hereafter, including but not limited to the provisions of the Export Administration Act of 1979, 50 U.S.C. Appx. §§ 2401 et seq., the Trading with the Enemy Act, 50 U.S.C. § 1 et seq., the Arms Export Control Act, 22 U.S.C. §§ 2778(a) and 2794(7), the International Emergency Economic Powers Act, 50 U.S.C. § 1701 et seq., and the Foreign Corrupt Practices Act, 15 U.S.C. §§ 78dd-1 et seq., and all regulations promulgated from time to time thereunder.

Marport reserves the right to immediately terminate the transactions contemplated hereby (without liability to Marport of any kind) if, in the opinion of Marport, any action taken by Buyer constitutes a violation of U.S. Export Control Laws or may subject Marport, its shareholders or any affiliated company of Marport to legal liability or loss of benefits under such law.

19. MISCELLANEOUS. The provisions of these Terms and Conditions shall be deemed severable, and the invalidity or unenforceability of any one or more of the provisions shall not affect the validity and enforceability of the remainder provisions of these Terms and Conditions, which shall remain in full force and effect. No provision hereof shall be deemed waived, amended or modified by either party unless such waiver, amendment or modification is in writing and signed by both parties. If the Products covered by these Terms and Conditions are to be supplied under a contract with a department or agency of the United States, Marport shall comply with any provisions of such contract that are construed as mandatory flow downs, but reserve the right to limit inspection or proprietary processes in areas that Marport may deem necessary. Any provisions which either expressly or by their nature is to continue after termination hereunder, on account of Buyer's default or otherwise, shall survive and remain in full force and effect. The captions or headings are for convenience only and are not intended to limit or define the scope or effect of any provision of these Terms and Conditions.

FINNMARK

★ **Kirkenes Marine Electronics**
P.O.Boks 37
9915 Kirkenes
Tlf: 78 99 65 80
kme@navy.no

Varanger Skipselctronikk
P.O.Boks 405
9811 Vadso
Tlf: 78 95 22 99
va-skips@online.no

A/S Radioservice
P.O.Boks F
9991 Båtsfjord
Tlf: 78 98 57 00
batsfjord@mobildata.no

Metek AS
P.O.Boks 153
9770 Mehamn
Tlf: 78 49 71 65
post@metek.no

Maritek A/S
P.O.Boks 31
9751 Honningsvåg
Tlf: 78 47 23 11
maritek@maritek.no

O.M.Rønning
P.O.Boks 490
9615 Hammerfest
Tlf: 78 41 17 85
post@omronning.no

Telrad Electronic AS
Strandgt. 16
9613 Hammerfest
Tlf: 78 42 95 00
telrad@telrad-electronic.no

★ **Havøysund Skipselctro AS**
Strandgata 85
9690 Havøysund
Tlf: 78 42 37 00

★ **Installatør R. Hansen**
Strandgata 20
9593 Breivikbotn
Tlf: 78 45 22 96

TROMS

★ **Installøren AS**
Eidkjosen
9100 Kvaløysletta
Tlf: 77 66 70 10
E-post: jeo@installatoren.no

Imes AS
P.O.Boks 2008
9265 Tromsø
Tlf: 77 66 46 00
imes@imes.no

J.M.Hansen
P.O.Boks 83
9273 Tromsø
Tlf: 77 66 55 00
firmapost@jmhansen.no

Nautik Elektronikk
P.O.Boks 458
9305 Finnsnes
Tlf: 77 84 26 60
nautik@navy.no

Harstad Elektronikk A/S
P.O.Boks 113
9490 Harstad
Tlf: 77 04 02 00
post@harstad-elektronikk.no

NORDLAND

Johnsen & Co Bø AS
Vinje
8470 Bø i Vesterålen
Tlf: 76 11 46 90
boe@navy.no

★ **Larsen Elcom AS**
Storgata 45
8430 Myre
Tlf: 76 13 42 50
E-post: larsen.elcom@online.no

★ **Multi Elektro AS**
8380 Ramberg
Tlf: 97 72 16 00
E-post: post@multi-elektro.no

★ **HIBOTech AS**
Eidet 2
8310 Kabelvåg
Tlf: 47 68 58 33
E-post: hans.inge.normann@lofotkraft.net

Johnsen & Co Hadsel AS
P.O.Boks 383
8455 Stokkmarknes
Tlf: 76 11 75 50
varehussjef.stokmarknes@elkjop.no

Sortland Skipselctro. AS
P.O.Boks 476
8401 Sortland
Tlf: 76 12 60 90

Navy Lofoten AS
Hatvikvn. 2
8373 Ballstad
Tlf: 76 05 44 00
ballstad@navy.no

Elektro Bodø AS
Jernbanevn.85
8037 Bodø
Tlf: 75 50 37 00
maritime@elektro.no

Myre Elektronikkservice A/S
P.O.Boks 98
8439 Myre
Tlf: 76 13 31 90
firmapost@meservice.no

Arne Bjørnvold A/S
P.O.Boks 14
8801 Sandnessjøen
Tlf: 75 04 02 18
abjoernv@online.no

TRØNDELAG

Arne Wahl-Olsen A/S
STRANDGATA 3c
7900 Rørvik
Tlf: 74 36 09 90
rorvik@navy.no

Argon AS
5425 Lade
7442 Trondheim
Tlf: 73 92 44 00
firmapost@argon.no

★ **Lagunen Holding AS**
Fossegrenda 30B
7038 Trondheim
Tlf: 91 37 34 04
E-post: roald@vaagen-boats.no

MØRE OG ROMSDAL

Elmarin AS
Heingsgt. 22
6507 Kristiansund
Tlf: 71 56 67 15
janove@elmarin.no

Oddstøl Elektronikk A/S
Hollendergt. 5-7
6509 Kristiansund
Tlf: 71 56 69 30
firmapost@oddstol.no

Sandbløst A/S
P.O.Boks 64
6501 Kristiansund
Tlf: 71 67 49 55
post@sandbløst.no

★ **Marineelektronikk AS**
P.O.Boks 5534 Hatlane
6024 Ålesund
Tlf: 40 00 40 95
E-post: geir@marineelektronikk.no

O.Øverland A/S
P.O.Boks 1098
6403 Molde
Tlf: 71 20 24 00
post@overland.no

★ **IF Elektro**
6094 Leinøy
Tlf: 47 01 25 00
E-post: if-elektro@mimer.no

Emil Langva A/S
Lorkenesgt. 3
6002 Ålesund
Tlf: 70 13 12 00
firmapost@emil-langva.no

Florvaag Elektronikk A/S
P.O.Boks 8050
6022 Ålesund
Tlf: 70 14 76 06
florvaag@florvaag.no

J. Weiberg Gulliksen AS
P.O.Boks 5094
6009 Ålesund
Tlf: 70 11 85 00
firmapost@gulliksen.no

HG Marine Electronics AS
6060 Hareid
Tlf: 70 10 13 90
electronics@hareidgroup.com

Ulstein Power & Control A/S
P.O.Boks 278
6067 Ulsteinvik
Tlf: 70 01 38 50
firmapost@ulsteingroup.com

SOGN OG FJORDANE

Måløy Radioforretn. AS
P.O.Boks 54
6701 Måløy
Tlf: 57 85 26 00
radiofor@online.no

Sigurd Solberg A/S
Fugleskjærgata 6
6900 Florø
Tlf: 57 75 13 00
post@sigurd-solberg.no

HORDALAND

Bergen Maritim Elektro AS
Damsgårdsstg.127
5162 Laksvåg
Tlf: 55 94 76 76
firmapost@bme-as.no

Navcom AS
Våggsgaten 22
5160 Laksevåg
Tlf: 55 50 64 10
navcom@navcom.no

ROGALAND

Vico A/S
P.O.Boks 204
4299 Avaldsnes
Tlf: 52 84 66 00
vico@vico.no

L.Larsen Elektronikk A/S
3023 Hillevåg
4095 Stavanger
Tlf: 51 88 68 68
mail@landorlarsen.no

IKM Elektro AS
Skvadronveien 24
4050 Sola
Tlf: 51 81 72 00
ikmelektro@ikm.no

★ **Navtronic AS**
Prinsens vei 10
4315 Sandnes
Tlf: 51 63 60 10
E-post: mail@navtronic.no

EL-Experten A/S
Gamle Sokndalsvn.38
4370 Egersund
Tlf: 51 49 60 08
post@el-experten.no

★ **Brommeland Elektronikk AS**
Lindangerveien 10
5519 Haugesund
Tlf: 99 33 15 00
E-post: post@brommeland.no

VEST-AGDER

Marin Elektro A/S
P.O.Boks 58
4551 Farsund
Tlf: 38 39 19 20
salg@marinelektro.no

AS Elektrisk Mandal
P.O.Boks 518
4504 Mandal
Tlf: 38 26 78 10
post@aselektrisk.no

AUST-AGDER

Elektro Skagerrak A/S
P.O.Boks 212
4952 Risør
Tlf: 37 14 39 14
post@elektro-skagerrak.no

VESTFOLD

IKM Instrutek AS
Elvevn. 28
3262 Larvik
Tlf: 33 16 57 00
ikminstrutek@ikm.no

Serco AS
Jarlsøveien 50
3124 Tønsberg
Tlf: 815 56 920
post@serco.no

★ **Maritime Support AS**
Varpedelet 4a
3728 Skien
Tlf: 45 40 08 00
E-post: maritime@support.as

OSLO & AKERSHUS

Sjøkaptein Lein AS
Akerhusstr. 30
0150 Oslo
Tlf: 22 42 78 40
m.lein@online.no

Vollen MarineSenter AS
Slemmestadveien 416
1390 Vollen
Tlf: 901 83 877
post@vollenmarinesenter.no

★ **Pollen Maritime AS**
Dronningen kontorsenter, Dronningen 1
0287 Oslo
Tlf: 91 77 14 51
E-post: post@pollenmaritime.no

ØSTFOLD

Tel-Rad A/S
P.O.Boks 544
1612 Fredrikstad
Tlf: 69 31 56 16
tel-rad@navy.no

★ **Stabil Data DA**
Svingen 5
1671 Kråkerøy
Tlf: 69 51 10 30
E-post: firmapost@stabildata.no

★ Only MaxSea dealers

